



# EWPX 174 AR(E)

controller for “forced air” refrigerating units  
with alarm output

## WHAT IT IS

EWPX 174 AR(E) is a single point temperature controller designed for applications in the field of commercial refrigeration.

The instrument provides two input probes for temperature control and defrost management plus four output relays for compressor, defrost system, evaporator fans and alarm management.

## HOW IT IS MADE

- **Housing:** plastic resin PC+ABS extinguishing grade V0
- **Size:** front panel 76x34 mm, depth 58 mm
- **Mount:** panel mount on 71x29 mm hole
- **Protection:** front IP65
- **Connections:** on screw terminal block for wires max 2.5 mm<sup>2</sup> (one wire only per block in compliance with VDE regulations)
- **Remote connection:** serial connection to the EWPX ECHO repeater (version /E only)
- **Serial connection:** TTL port for the connection to the EWRS 485 interface for Televis system linking
- **Display:** 3 digit plus “ - ” sign; digit height 12.5 mm
- **Main outputs:** 1 on N.O. relay 8(3)A 250V AC for the compressor and 2 on N.O. relay outputs 5(2)A 250V AC for evaporator fans and defrost system
- **Alarm output:** 1 on N.C. relay 8(3)A 250V AC
- **Analogue inputs:** NTC probes for temperature control and defrost management
- **Resolution:** 1 °C, 0.1 °C, or 0.5 °C, selectable through parameters
- **Consumption:** 3 VA (5 VA in the “/E” version with the EWPX ECHO module connected)
- **Power supply:** 12 Vac/dc ±15%

## GENERAL DESCRIPTION

EWPX 174 AR(E) is a single point temperature controller designed for applications in the field of commercial refrigeration.

The instrument provides two input probes for temperature control and defrost management plus four output relays for compressor, defrost system, evaporator fans and alarm management. As a standard feature it can be connected to the Televis system. The “/E” version can also be connected to the EWPX ECHO data repeater, which allows remote display of the temperature measured by the instrument. The instrument can be configured according to the application through a series of parameters - it is supplied in the new 32x74 mm cabinet (ELIWELL Standard).

## COMMANDS ON FRONT PANEL

The instrument is provided with two keys: “UP” and “SET/DOWN”.

**SET/DOWN:** by pressing and releasing it the Setpoint is displayed, the “set” led is turned on.

To change the Setpoint value use the “UP” and “SET/DOWN” keys within 5 seconds. If no operation is performed for more than 5 seconds normal mode is restored and the new value is automatically acquired.

The same button is used to increase values during Setpoint change or parameters programming. When held pressed a fast increase is performed.

**UP:** button used for value increase, used to change both the Setpoint and the parameters. A fast increase is obtained by holding it pressed. This key also allows manual start of the defrost cycle, by holding it pressed for more than 5 seconds (this function is not enabled during Setpoint or parameter programming). During the manual defrost cycle the “DEFROST” led will blink.

**“COMPRESSOR” Led:** led related to the compressor relay; it is on when the compressor works.

**“SET” Led:** it is on during Setpoint display and programming; it blinks during parameter programming.

**“DEF” Led:** status light of the defrost. It is on during automatic defrost; it blinks during manual defrost.

**“ALARM” Led:** led related to the alarm. It is on when the alarm is active or disabled due to the exclusion time (see parameters “PAO”, “dAo” and “tAo”); it blinks when the alarm is silenced.

## DISPLAYING AND SETTING THE SETPOINT

To display the Setpoint value press and release “SET/DOWN”; the Setpoint value is displayed and the “set” led is turned on.

To change the Setpoint value operate on keys “UP” and “SET/DOWN” within 5 seconds; after such time normal mode will be restored.

## MANUAL ACTIVATION OF THE DEFROST CYCLE

The manual activation of the defrost cycle starts by holding the “UP” key pressed for more than 7 seconds (the key is not active during Setpoint or parameter programming). In case the defrost conditions are not suitable (e.g. the temperature of the evaporator probe exceeds the end defrost temperature) the display will show the blinking “dFu” (deFrost unable) label. During manual defrost the “DEFROST” led blinks.

## SILENCING THE ALARM

An alarm condition is signalled by the “ALARM” led and the activation of the related relay on the terminal block.

The alarm can be silenced by pressing any



key on the front panel; the relay will be disabled and the led will blink until the end of the alarm condition.

### DISPLAYING PROBE VALUES

The instrument provides two probe inputs: temperature control and defrost management. The pressure and release of the "UP" and "SET/DOWN" keys simultaneously causes the label "CPr" (Compressor Probe) to be displayed; by pressing and releasing the "SET/DOWN" key the display shows the value on the control probe. By pressing the "UP" key the display shows the label "EPr" (Evaporator Probe); by pressing and releasing the "SET/DOWN" key the display shows the value of the defrost probe.

### KEYBOARD LOCKING

A special programming of the "Loc" parameter allows to disable the keyboard in order to avoid unauthorised operations or parameter changes.

When the keyboard is disabled the Setpoint and the parameters can only be displayed (not changed), except parameter "Loc" to allow keyboard release.

### PASSWORD TO ACCESS PARAMETER PROGRAMMING

A password can be set to allow access to the parameter programming phase. To set (or change) the password access parameter "PAS" and type a number from 1 to 15 (0 to disable the password). The password will be enabled when exiting from the parameter programming phase.

In case the password is enabled, when requesting access to the parameter programming phase the label "PAS" is displayed. Press the "SET/DOWN" key to access password programming and change it using keys "UP" and "SET/DOWN". If the password is correct the pressure of keys "SET/DOWN" and then "UP" enables access to the programming phase, otherwise it will automatically quit.

### PARAMETERS PROGRAMMING

The programming phase can be accessed pressing the "UP" and "SET/DOWN" keys simultaneously for more than 7 seconds. The first label is displayed and the "set" led starts blinking. To access other parameters press "UP" or "SET/DOWN"; to display the value of the parameter shown on the display press "UP" and "SET/DOWN" simultaneously. To change its value press "UP" or "SET/DOWN".

The storage of new values takes place automatically when exiting the programming mode (no key pressed for some seconds).

### PARAMETERS DESCRIPTION

**diF:** diFferential.

Setpoint intervention differential.

For applications in the field of refrigeration the differential shall be set to positive val-

## DEFAULT SETTINGS - STANDARD MODELS

Parameter	Description	Range	Default	Unit
diF	diFferential	-12...12	2	°C / °F
LSE	Lower SEt	-999...HSE	-50	°C / °F
HSE	Higher SEt	LSE...999	40	°C / °F
dtY	defrost type	EL / in	EL	flag
dit	defrost interval time	0...31	6	hours
dct	defrost counting type	dF / rt / SC / Fr	dF	flag
doh	defrost offset hour	0...59	0	minutes
dEt	defrost Endurance time	1...250	30	minutes
dSt	defrost Stop temperature	-999...999	8	°C / °F
FSt	Fan Stop temperature	-999...999	2	°C / °F
Fdt	Fan delay time	0...250	0	minutes
dt	drainage time	0...250	0	minutes
dPo	defrost (at) Power-on	n / y	n	flag
ddL	defrost display Lock	n / y / Lb / Lg	n	flag
dFd	defrost Fan disable	n / y	y	flag
Att	Alarm temperature type	Ab / re	re	flag
HAL	Higher ALarm	-999...999	50	°C / °F
LAL	Lower ALarm	-999...999	-50	°C / °F
AFd	Alarm (Fan) differential	1...50	2	°C / °F
PAO	Power-on Alarm Override	0...10	2	hours
dAo	defrost Alarm override	0...999	60	minutes
tAo	temperat. Alarm override	0...250	0	minutes
Fco	Fan compressor off	oF / on	on	flag
cPP	compressor Probe Prot.	oF / on / dc	on	flag
Ont	On time (compressor)	0...250	10	minutes
OFt	OFF time (compressor)	0...250	10	minutes
ctP	compr. type Protection	nP/don/doF/dbi	doF	flag
cdP	compr. delay Protection	0...15	0	minutes
odo	output delay (at) on	0...99	0	minutes
PrP	Presence Probe	nP / EP / AP / EAP	EP	flag
CAL	CALibration	-12...12	0	°C / °F
dEA	dEvice Address	0...14	0	number
FAA	FAMily Address	0...14	0	number
AOP	Alarm Output Polarity	di / in	in	flag
ndt	number display type	int / dEc / hFn	int	flag
Loc	(keyboard) Lock	n / y	n	flag
PAS	PASsword	0...15	0	number
rEL	rELease firmware	/	/	/
tAb	tAbLe of parameters	/	/	/

ues; the compressor will stop when the Setpoint is reached (according to the control probe) and start again when the temperature reaches the Setpoint plus the differential.

**LSE:** Lower SET.

Minimum value that can be assigned to Setpoint.

Usually set to the minimum value measurable by the probe.

**HSE:** Higher SET.

Maximum value that can be assigned to Setpoint.

**dtY:** defrost type.

EL = electric defrost;

in = cycle inversion defrost (hot gas).

**dit:** defrost interval type.

Defrost interval in hours or minutes.

**dct:** defrost counting type.

Counting mode for the defrost interval.

dF = digifrost Feature (Digifrost® method; only the operation time of the compressor is counted).

rt = real time (the count is based on the operating time of the instrument).

SC = Stop Compressor (the defrost takes place whenever the compressor stops).

Fr = Free (the compressor relay has no relation with the defrost functions and continues to regulate on Setpoint).

**doh:** defrost offset hour.  
 Defrost start delay time; in minutes.

**dEt:** defrost Endurance time.  
 Defrost time-out; in minutes or seconds.

**dSt:** defrost Stop temperature.

**FSt:** Fan Stop temperature.  
 When the temperature measured by the defrost probe exceeds a set value, fans are stopped.

**Fdt:** Fan delay time.  
 Delay for fan start after defrost; in minutes.

**dt:** drainage time.  
 Dripping time in minutes.

**dPo:** defrost (at) Power-on.  
 y = yes;  
 n = no

**dDL:** defrost display lock.  
 n = no; during defrost the display will show the temperature measured by the room probe.  
 y = yes; during defrost the display will show the last value measured by the room probe before defrost.

Lb = Label (“defrost”); during defrost the display will show the “dEF” (dEFrost) label to indicate defrost is in progress.

Lg = Label (“degivrage”); during defrost the display will show the “dEg” (“dEgivrage”) label to indicate defrost is in progress.

NOTE: in case “n” or “lb” is selected the display will be locked until the Setpoint on the room probe is reached.

**dFd:** defrost Fan disable.  
 Allows the selection of fan evaporator exclusion during defrost.  
 y = yes;  
 n = no.

**Att:** Alarm temperature type.  
 Decoding mode for parameters “HAL” and “LAL”.

Ab = Absolute;  
 re = relative.

**HAL:** Higher ALarm.  
 Maximum temperature alarm.

**LAL:** Lower ALarm.  
 Minimum temperature alarm.

**Afd:** Alarm (Fan) differential.  
 Operating differential for temperature alarms.

**PAO:** Power-on Alarm Override.  
 Alarm exclusion after instrument start-up; in hours.

**dAo:** defrost Alarm override.  
 Alarm exclusion after defrost; in minutes.

**tAo:** temperature Alarm override.  
 Delay for temperature alarm signalling; in minutes.

**Fco:** Fan compressor off.  
 Allows to disable or enable the fan lock when the compressor is OFF.  
 oF = disabled;  
 on = enabled.

**cPP:** compressor Probe Protection.  
 Allows the selection of the output state in case of faulty probe.  
 oF = relay OFF in case of faulty probe.  
 on = relay ON in case of faulty probe.  
 dc = duty cycle; the ON and OFF times for the relay are defined by parameters “Ont” and “OFt”.

## CONNECTIONS

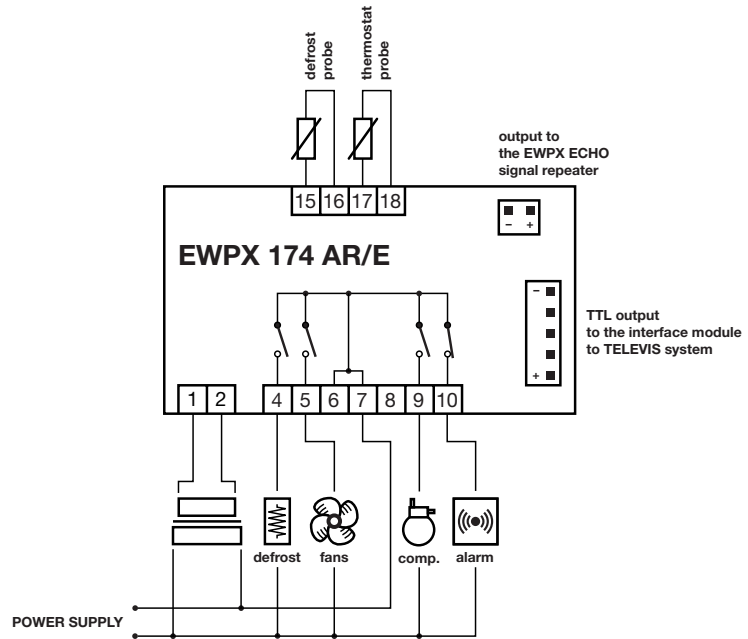

**Ont:** On time (compressor).  
 ON time for the compressor (when CPP = dc); in minutes.

**OFt:** OFF time (compressor).  
 OFF time for the compressor (when CPP = dc); in minutes.

**ctP:** compressor type Protection.  
 Allows the selection of the protection type to prevent close startups of the output (time is set through the following parameter).  
 nP = no Protection.  
 don = delay on start. Delay on relay activation.  
 doF = delay at switching oF. Minimum time for relay cut off.  
 dbl = delay between two successive starts.

**cdP:** compressor delay Protection.  
 Time referred to the previous parameter; in minutes.

**odo:** output delay (at) on.  
 Delay for the activation of outputs at start-up; in minutes.

**PrP:** Presence Probe.  
 Allows to select the presence of the Evaporator probe.  
 nP = Evaporator probe not present;  
 EP = Evaporator probe present;  
 AP = not usable;  
 EAP = not usable.

**CAL:** CALibration.  
 Allows the calibration of the value measured by the control probe in case it is different from a sample value.  
 Default set to “0”.

**dEA:** dEvice Address.  
 Allows the selection of the device address in the remote control network.

**FAA:** Family Address.  
 Allows the selection of the device family in the remote control network.

**AOP:** Alarm Output Polarity.  
 di = direct;

in = inverted.

**ndt:** number of digits.  
 Type of display.

Int = reading without decimal point;  
 dEc = reading with decimal point, resolution 0.1 °C;  
 hFn = reading with decimal point, resolution 0.5 °C.

**Loc:** keyboard Lock.  
 Allows to disable the keyboard to prevent unauthorised operations. When the keyboard is disabled only display (not modification) of Setpoint and parameters is allowed. Only the “Loc” parameter can be modified to permit keyboard unlock.  
 y = yes;  
 n = no.

**PAS:** PASsword.  
 Allows to set a password (see paragraph “Password to access parameter programming”).  
 0 = no password required to access parameter programming;  
 1...15 = available values for the password.

**rEL:** rELease firmware.  
 Read-only parameter showing the release code of the product.

**tAb:** tAbles of parameters.  
 Summary of factory set parameters; cannot be modified by the user.

## MECHANICAL MOUNT

The instrument is designed for panel mount. Drill a 29x71 mm hole and introduce the instrument, then fix it with the special bracket (included).  
 The operating temperature range for correct operation is from -5 to 65 °C.  
 Do not install the instrument in moist and/or dirty places; it is suitable for operation in environments with an ordinary pollution level. Leave enough room for air circulation by the cooling holes of the instrument.

## ELECTRICAL CONNECTIONS

EWPX 174 AR(/E) is provided with four relay outputs, one serial output for the connection to the Televis system and another serial output for the EWPX ECHO repeater (version /E only). The instrument includes a screw terminal block for the connection of electrical cables with a maximum 2.5 mm<sup>2</sup> section (one wire only for each block, according to VDE regulations).

Relay outputs, connected through two common terminal blocks, are free from voltage. Do not exceed the maximum allowed current (alarm and compressor: 8(3)A 250V AC evaporator fans and defrost: 5(2)A 250V AC). In case of heavier loads use a suitable power contactor.

Check the power voltage complies with the instrument requirements: 12 Vca/cc ±15% (very low safety voltage).

The two NTC probes have no insertion polarity and can be lengthened using a common bipolar cable (bearing in mind that very long probes imply worse instrument performances referred to the EMC). Outputs for the connection of the EWPX ECHO repeater (version /E only) and the EWRS 485 interface module of the Televis system require connections according to the indicated polarity.

The probe cable, the connection cable for the EWPX ECHO repeater (version /E only), the connection cable for the EWRS 485 interface module shall be kept far from the relay cables both for EMC and safety reasons. The coordinated European safety regulations state that the relay contacts (and generally speaking, all parts subject to dangerous voltage) shall be kept away from the very low safety voltage connections (probe, Televis serial, power supply) using insulation systems and distances providing at least a double or reinforced insulation.

However EMC requirements for correct operation suggest/impose better accuracy in such separation by using separated insulating pipes and special cable fixing systems.

EWPX ECHO (version /E only) operates at very low safety voltage and shall be installed respecting the same insulation/separation conditions from the parts bearing voltage and the wires of the relay contacts.

## ERROR MESSAGES

EWPX 174 AR(/E) displays error message "E1" in case of shorted, interrupted or disconnected probe. The message is also displayed in case of "under range", i.e. when the lower display limit (-55 °C) is exceeded, or in case of "over range", i.e. when the upper display limit (125 °C) is exceeded. Error message "E2" refers to the evaporator probe (defrost end) for the same reasons as above.

In case of error the Televis system alarm is immediately activated.

Before replacing the probe check its connections.

## TECHNICAL DATA

**Housing:** plastic resin PC+ABS extinguishing grade V0.

**Size:** front panel 76x34 mm, depth 58 mm.

**Mount:** panel mount on 71x29 mm hole.

**Protection:** front IP65.

**Connections:** on screw terminal block for wires max 2.5 mm<sup>2</sup> (one wire only per block in compliance with VDE regulations).

**Remote connection:** serial connection to the EWPX ECHO repeater (version /E only).

**Serial connection:** TTL port for the connection to the EWRS 485 interface for TELEVIS system linking.

**Display:** 3 digit plus "-" sign; digit height 12,5 mm.

**Commands:** all located on front panel.

**Data storage:** on non-volatile memory (EEPROM).

**Operating temperature:** -5...65 °C; (23...149 °F).

**Storage temperature:** -30...75 °C; (-22...167 °F).

**Main outputs:** 1 on N.O. relay 8(3)A 250V AC for the compressor and 2 on N.O. relay outputs 5(2)A 250V AC for evaporator fans and defrost system.

**Alarm output:** 1 on N.C. relay 8(3)A 250V AC.

**Analogue inputs:** NTC probes for temperature control and defrost management.

**Range:** -50...100 °C (-58...212 °F).

**Resolution:** 1 °C, 0.1 °C, or 0.5 °C, selectable through parameters.

**Accuracy:** better than 0.5% on full range.

**Consumption:** 3VA (5 VA in the "/E" version with the EWPX ECHO module connected).

**Power supply:** 12 Vac/dc ±15%.

## DISCLAIMER

This manual and its contents remain the sole property of Invensys Controls Italy s.r.l., and shall not be reproduced or distributed without authorization. Although great care has been exercised in the preparation of this document, Invensys Controls Italy s.r.l., its employees or its vendors, cannot accept any liability whatsoever connected with its use. Invensys Controls Italy s.r.l. reserves the right to make any changes or improvements without prior notice.



**Invensys Controls Italy s.r.l.**

via dell'Industria, 15 Zona Industriale Paludi

32010 Pieve d'Alpago (BL) ITALY

Telephone +39 0437 986111

Facsimile +39 0437 989066

Email [info@climate-eu.invensys.com](mailto:info@climate-eu.invensys.com)

Internet <http://www.climate-eu.invensys.com>

**7/2001 ing**  
**cod. 9IS40066**